

B-FM

Series 多袋式袋濾機(側進底出) Multi-bags Filter Housing(Side In & Bottom Out) マルチタイプバッグハウジング(Inシェル側・Outボトム側)

設計壓力 Design P. 10kg/cm²
設計圧力 操作壓力 Operating P. 7kg/cm²
操作圧力

設計溫度 Design T. 100°C
設計溫度 操作溫度 Operating T. 75°C
操作溫度

選購配件 Accessory オプション品(別売り)
各式濾袋、壓袋器、濾袋撐開架、金屬浮球
Filter bag. Bag pressing. Bag bracket. Metal float ball
バッグエレメント・バッグ押え金具・バッグプロテクター・バルーン

濾袋規格 Bag specifications バッグ寸法
2 # 號袋 Filter bag No.2 ロングタイプ (#2)



2 BFM SB 4 80 10K E 12

濾袋數 QTY of Bag エレメント數量 2 ~ 12	產品代碼 Product code 商品コード	出入口方式 In & Outlet Type 出入口位置 SB - 側進底出 Side In & Bottom Out SB - INシェル側・OUTボトム側	材質 Material 材質 4 - 304 6 - 316 6L - 316L	出入口規格 In & Outlet Size 出入口寸法 50 - 2" 65 - 2-1/2" 80 - 3" 90 - 3-1/2" 100 - 4" 125 - 5" 150 - 6" 200 - 8" 250 - 10"	出入口類型 In & Outlet Type 出入口規格 10K - JIS 150P - ANSI PN10 - DIN J - Clamp PF - BSPT-F BF - BSPF-F NF - NPT-F	O型環材質 O-ring Material Oリング材質 E - EPDM V - Viton N - NBR S - Silicone TV - Teflon + Viton	内面表面處理 Interior surface finished 内面仕上げ 1 - 酸洗 / 酸洗淨 ACID - Washing 2 - 電解 / 電解研磨 Electrolyze 3 - 拋光 / ハブ研磨 Polishing 外面表面處理 Exterior surface finished 外面仕上げ 1 - 酸洗 / 酸洗淨 ACID - Washing 2 - 電解 / 電解研磨 Electrolyze 3 - 拋光 / ハブ研磨 Polishing
----------------------------------------	-------------------------------	------------------------------------------------------------------------------------------------	---------------------------------------------------------	-----------------------------------------------------------------------------------------------------------------------------------------------------	---------------------------------------------------------------------------------------------------------------------------------------	---------------------------------------------------------------------------------------------------------------	----------------------------------------------------------------------------------------------------------------------------------------------------------------------------------------------------------------------------------------------------------------------------------------------

Multi-bags Filter Housing(Side In & Bottom Out)

No.	名稱	Description	No.	名稱	Description	No.	名稱	Description
1	螺桿	Screw	8	O型環	O-ring	15	桶體	Shell
2	轉盤	Turntable	9	桶唇	Shell flange	16	濾袋座	Filter bag plate
3	吊架(桿)	Davit arm	10	單眼螺絲座	Eye bolt socket	17	金屬內網	Basket
4	排氣口	Vent	11	心軸	Spindle	18	端板	Bottom cover
5	上蓋	Top cover	12	單眼螺絲	Eye bolt	19	腳架	Support leg
6	上蓋唇	Top cover flange	13	華司	Washer	20	排放口	Drain
7	環首螺母座	Eye nut socket	14	環首螺母	Eye nut	21	進/出水口	Port(Inlet/Outlet)

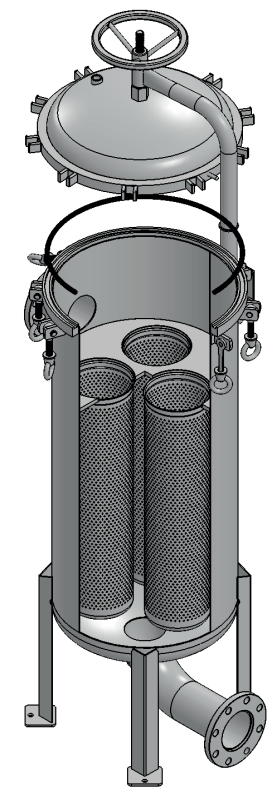
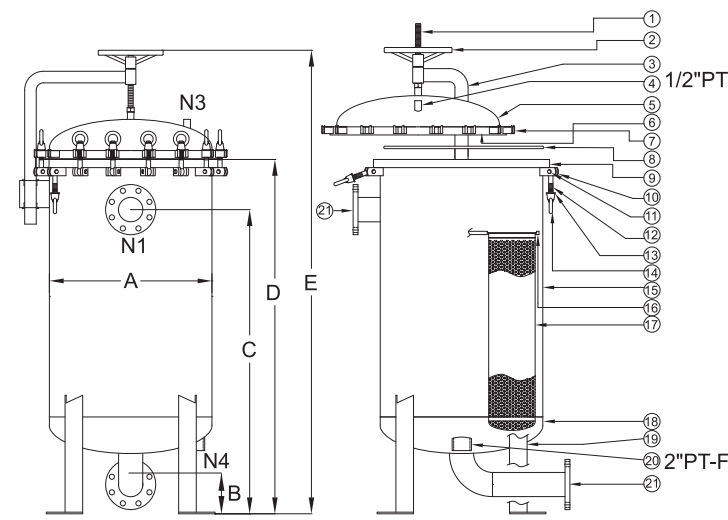
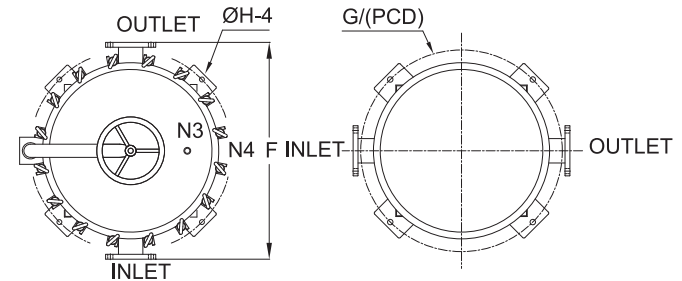

型式 Model	In and Outlet Size	QTY of Bags	A m/m	B m/m	C m/m	D m/m	E m/m	F m/m	G/(PCD) m/m	H m/m	M ³ /Hr	重量 Weight	容量 Volume
2BFM2	3"	2	Ø406	108	1086	1271	1642	606	Ø516	Ø14	90	97kg	116L
2BFM2	4"	2	Ø406	127	1157	1367	1738	606	Ø516	Ø14	90	102kg	117L
3BFM2	3"	3	Ø486	108	1102	1287	1673	686	Ø596	Ø14	135	125kg	188L
3BFM2	4"	3	Ø486	127	1172	1382	1768	686	Ø596	Ø14	135	130kg	189L
4BFM2	3"	4	Ø508	108	1106	1291	1681	708	Ø618	Ø14	180	161kg	244L
4BFM2	4"	4	Ø508	127	1177	1387	1777	708	Ø618	Ø14	180	169kg	245L
4BFM2	6"	4	Ø508	152	1300	1535	1925	708	Ø618	Ø14	180	206kg	279L
5BFM2	3"	5	Ø560	108	1117	1302	1703	760	Ø704	Ø18	225	160kg	244L
5BFM2	4"	5	Ø560	127	1188	1398	1799	760	Ø704	Ø18	225	165kg	278L
5BFM2	6"	5	Ø560	152	1311	1546	1947	760	Ø704	Ø18	225	206kg	246L
6BFM2	3"	6	Ø600	108	1125	1310	1729	800	Ø744	Ø18	270	198kg	277L
6BFM2	4"	6	Ø600	127	1196	1406	1825	800	Ø744	Ø18	270	202kg	278L
6BFM2	6"	6	Ø600	152	1319	1554	1973	800	Ø744	Ø18	270	206kg	279L
7BFM2	3"	7	Ø600	108	1125	1310	1729	800	Ø744	Ø18	315	430kg	488L
7BFM2	4"	7	Ø600	127	1196	1406	1825	800	Ø744	Ø18	315	440kg	489L
7BFM2	6"	7	Ø600	152	1319	1554	1973	800	Ø744	Ø18	315	450kg	491L
7BFM2	8"	7	Ø600	184	1439	1714	2133	800	Ø744	Ø18	315	440kg	493L
8BFM2	4"	8	Ø650	127	1205	1415	1843	850	Ø794	Ø18	315	450kg	489L
8BFM2	6"	8	Ø650	152	1329	1564	1992	850	Ø794	Ø18	360	450kg	491L
8BFM2	8"	8	Ø650	184	1448	1723	2151	850	Ø794	Ø18	360	460kg	493L
9BFM2	6"	9	Ø762	152	1352	1587	2164	962	Ø962	Ø19	405	520kg	564L
9BFM2	8"	9	Ø762	184	1473	1748	2325	962	Ø962	Ø19	405	530kg	566L
10BFM2	6"	10	Ø762	152	1352	1587	2164	962	Ø962	Ø19	450	590kg	662L
10BFM2	8"	10	Ø762	184	1473	1748	2325	962	Ø962	Ø19	450	600kg	664L
10BFM2	10"	10	Ø762	216	1602	1927	2504	962	Ø962	Ø19	450	715kg	854L
12BFM2	8"	12	Ø813	184	1483	1758	2345	1013	Ø1013	Ø19	540	725kg	852L
12BFM2	10"	12	Ø813	216	1613	1938	2525	1013	Ø1013	Ø19	540	735kg	854L